

# Validation of the adjusted strength criterion LaRC04 for uni-directional composite under combination of tension and pressure

J. Krystek<sup>a,\*</sup>, R. Kottner<sup>a</sup>, L. Bek<sup>a</sup>, V. Laš<sup>a</sup>

<sup>a</sup>Faculty of Applied Sciences, University of West Bohemia, Univerzitní 22, 306 14 Plzeň, Czech Republic

Received 25 February 2010; received in revised form 25 October 2010

---

## Abstract

Strength of unidirectional composite materials for some combinations of state of stress cannot be successfully predicted even with modern failure criteria. In case of the combination of compression in the transverse direction and tension in the fiber direction, the criterion LaRC04 was adjusted in previous work. The predicted strengths in this case reach significantly larger values compared to the ultimate strengths of the material in the respective directions. The adjusted criterion is able to predict the failure of unidirectional composite in case of the mentioned combination of loading. The validation of the adjusted criterion is carried out by means of the comparison of experimental results and numerical analysis performed in finite element system MSC.Marc.

© 2010 University of West Bohemia. All rights reserved.

*Keywords:* composite, criterion, LaRC04, combination of tension and compression

---

## 1. Introduction

One way how to joint composite and metal parts is using pins. The wrapped pin joints were used in case of joint of CompoTech composite hydraulic cylinder (see Fig. 1) and metal cylinder flange, where the joint is exposed to tension. The main principle of producing the wrapped pin joints is that fibres of the composite are wrapped directly around the shape of a metal pin. It allows creating the joint without cutting fibres. Therefore, it allows creating joints that excel at strength. The tensile loading of the joint results in press in the inner diameter of the pin holes (loops), where the state of stress corresponds to loading of pressure vessel. Compression in the transverse direction (perpendicular to composite fibres) and tension in the longitudinal direction (parallel to composite fibres) reach very large values compared with ultimate strengths of material in the respective directions (see Fig. 1c).

During the investigation of the problem of pin joints in composites, several works about the joint failure were studied [1, 2, 3, 6, 11, 13]. However, only limited works were focused on the wrapped pin joints [4, 7], where the mentioned specific state of stress occurs. In work [4], the strength criterion Puck for prediction of failure of the wrapped pin joints was used. Using this criterion, major disagreement between numerical and experimental results was achieved. Also in work [7], no standard criterion for correct prediction of failure of the joint was found. Therefore, the criterion LaRC04 [12] was adjusted [7, 8].

The aim of this work is the validation of the adjusted strength criterion LaRC04 for unidirectional composite under combination of tension and compression for a wider range of geometries

---

\*Corresponding author. Tel.: +420 377 632 341, e-mail: krystek@kme.zcu.cz.

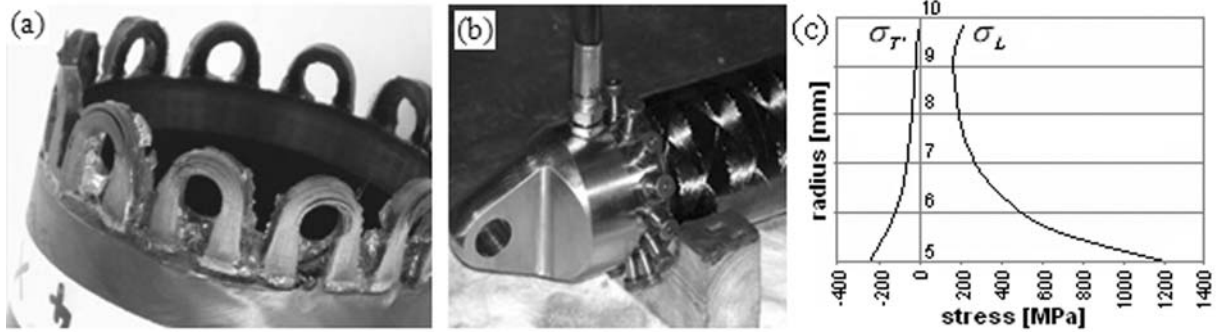

Fig. 1. (a) Composite parts of wrapped pin joint integrated in CompoTech hydraulic cylinder [7]; (b) CompoTech hydraulic cylinder [7]; (c) Stress dependences in loop [7]

than in [7, 8]. The validation of the adjusted strength criterion was carried out by means of comparison of experimental results and numerical analysis. The numerical analysis was performed in finite elements system MSC.Marc.

## 2. Failure criterion LaRC04

The criterion LaRC04 is a strength criterion for unidirectional composite materials developed in NASA Langley Research Center in 2004 [12]. It belongs to the group of so-called interactive criteria and so-called *direct mode* criteria. Interactive criteria include relationship between components of normal stresses and between components of normal stresses and components of shear stresses. Criterion LaRC04 is derived for full three-dimensional state of stress. Direct mode criteria distinguish several types (modes) of failure and describe each of them with independent condition. Result from criterion LaRC04 is the value of failure index. (The failure index takes the value from 0 to 1. If the failure index is equal to 1, the failure occurs.)

In the mentioned application of joint elements of the hydraulic cylinder, the three-dimensional model showed major disagreement between numerical and experimental results for failure modes LaRC04#2 and LaRC04#3 [7]. Therefore, the criterion LaRC04 was modified [7, 8]. In case of mode LaRC04#2 (matrix failure in compression in the transverse direction), it was found that the influence of stress in the fiber direction  $\sigma_L$  should be included in this mode. The equation for failure index of failure mode LaRC04#2 was adjusted to

$$FI_M = \left( \frac{\tau^T}{S^T - \eta^T \sigma_n + \sigma_L P_M} \right)^2 + \left( \frac{\tau^L}{S^L - \eta^L \sigma_n + \sigma_L P_M} \right)^2 \leq 1, \quad (1)$$

where the term  $\sigma_L P_M$  is the suggested adjustment. In case of mode LaRC04#3 (fiber failure in tension in the longitudinal direction), the equation for failure index was adjusted to

$$FI_F = \frac{\sigma_L}{X^T P_F} \leq 1, \quad (2)$$

where  $P_F$  is again the suggested adjustment.

## 3. Sample manufacture and experiments

The special samples for the validation of adjusted strength criterion were proposed. Circular part of sample in which is achieved the investigated combination of stress will be named as loop. Design of sample and designation of geometric parameters are illustrated in Fig. 2, where  $d$  is the diameter of the pins,  $t$  is the thickness of the loop,  $a$  is the width of the loop and  $l$  is the distance between the axes of pins.

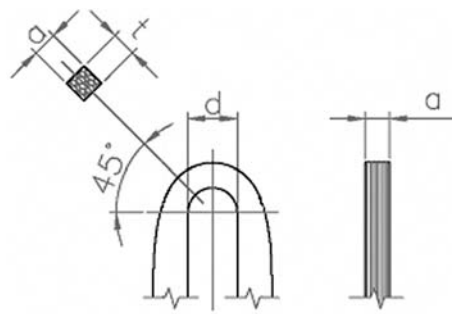

Fig. 2. Sample geometric properties [7]

The samples for experiments were produced in laboratory at Department of Mechanics, University of West Bohemia in Pilsen. Technology of filament winding was used for production of samples (Fig. 3). The fibres were impregnated and wound on the structure with pins. The samples were then hardened in oven.

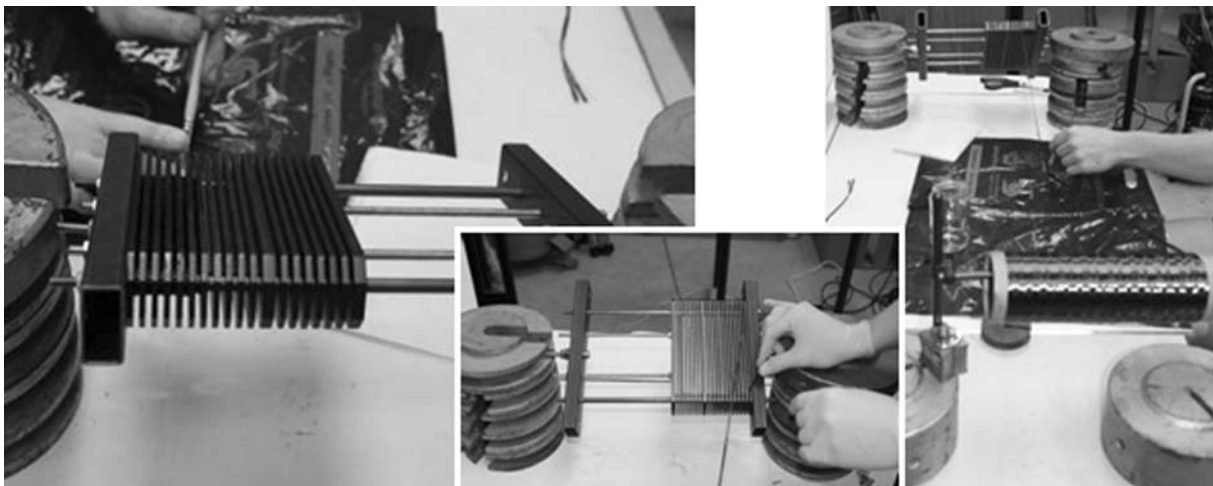

Fig. 3. Manufacture of samples

The carbon fiber T700 and epoxy resin (the resin LG120 and the hardener EM100 in ratio 100 : 34) was used for production of the uni-directional composite samples. The fiber volume of loops was  $V_f = 0.65$ . Elasticity parameters in the material directions are presented in Tab. 1 and Tab. 2. Strength parameters are presented in Tab. 2.

Table 1. Elasticity parameters of composite

$V_f$ [-]	$E_L$ [MPa]	$E_T$ [MPa]	$E_{T'}$ [MPa]	$\nu_{LT}$ [-]	$\nu_{TT'}$ [-]	$\nu_{T'L}$ [-]	$G_{LT}$ [MPa]	$G_{TT'}$ [MPa]	$G_{T'L}$ [MPa]
0.65	153 730	5 940	5 940	0.335	0.332	0.013	2 755	2 230	2 755

Table 2. Strength parameters of composite

$X^T$ [MPa]	$Y^T$ [MPa]	$Y^C$ [MPa]	$S^L$ [MPa]	$\alpha_0$ [°]
3 264	42	92	48	55

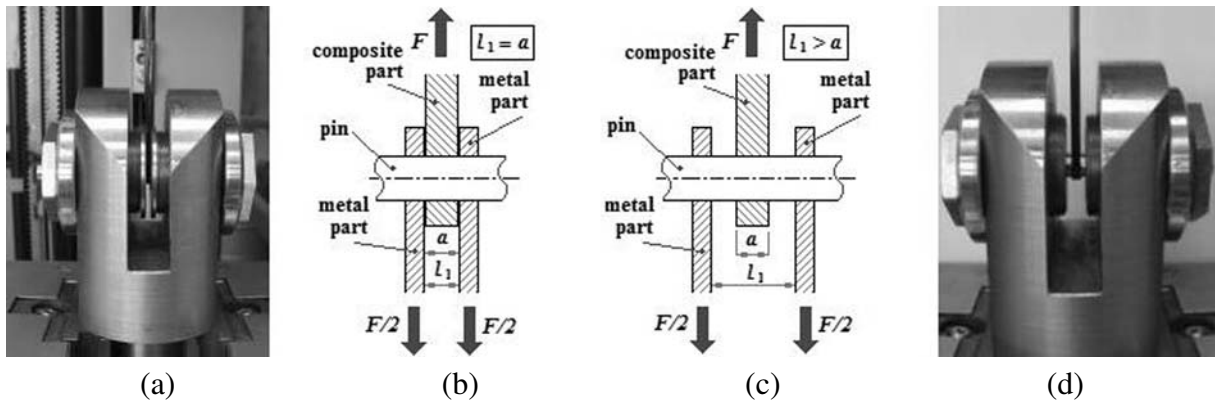

Fig. 4. (a), (b) Tight fastening; (c), (d) Free fastening

The loading was carried out by means of the machine Zwick/Roell Z050. The experimental samples were tested in tension. Each sample was fixed in the machine by means of the special components (see Fig. 4a and 4d) that were fixed in the jaws of the machine. These components allow the loading of samples with wide range of geometric parameters. Using these components, it is possible to select between two kinds of fastening of samples — tight fastening (further TF) and free fastening (further FF) (see Fig. 4). The faces of the FF loop are free. In case of the TF loop, the faces are tight fastened near the area of pin. This corresponds to fixture washers and nuts in real hydraulic cylinder.

The value of maximal tensile force was the parameter for comparison between numerical results and experimental results. The failure of fibres occurs at this maximal tensile force. The limiting factors for experiments were maximal tensile force 50 kN (maximal loading force in the used machine) and strength of metal pin with smaller diameter.

More than 150 samples with different geometries (see Fig. 5.) ( $d = 8$  and  $12$  mm;  $a = 3$  and  $6$  mm,  $t = 1 \div 8$  mm) were tested at the temperature of  $+20$  °C. The loading speed was  $v = 0.5$  mm/min.

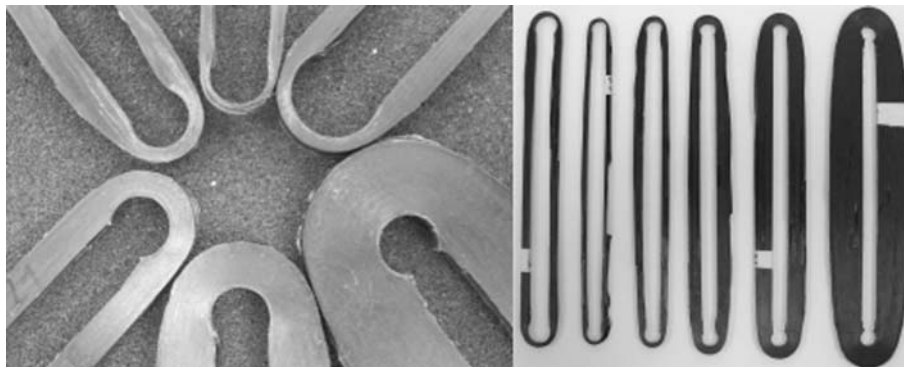

Fig. 5. Samples with different geometries

#### 4. Failure of the samples

The matrix failure occurred prior to the fiber failure for some samples. The matrix failure divides the loop cross-section of the sample. A shape of separated part in case of the FF samples (the displacement in the pin axial direction is allowed) is obvious from Fig. 6a,b. In the separated part of cross-section, the decrease of stress in longitudinal direction  $\sigma_L$  occurred. Whilst, increase of stress in longitudinal direction  $\sigma_L$  in not separated part of cross-section occurred.

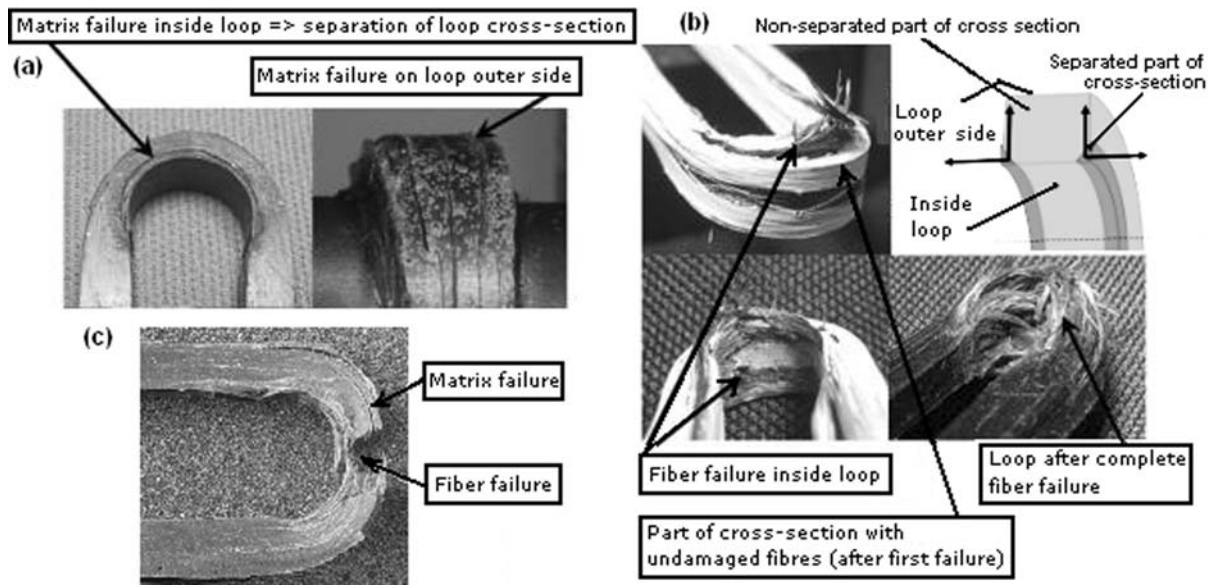

Fig. 6. (a), (b) Failure procedure of FF sample [7]; (c) Failure procedure of TF samples

Therefore, failure of fiber due to influence of tension began earlier than in case without separation of part of cross-section. The loop strength was considered as the maximal tensile force for failure of fiber (failure index of fiber  $FI_F = 1$ ) [7, 8, 10]. “Layer separation” of the loop cross-section in case of TF samples is obvious from Fig. 6c. This separation had not the influence on the loop strength.

### 5. Numerical simulation

A three-dimensional numerical model was created in the finite elements system MSC.Marc. The adjusted strength criterion LaRC04 was implemented in this finite element system [9]. The model was created from hexahedral elements with 8 nodes (SOLID elements). Regarding symmetry of the sample, only one eighth of the sample was modelled (see Fig. 7b). Orthotropic material properties were assigned to the elements respecting the orientation of the fibers. The loading was controlled by the displacement of a rigid surface, which simulates the pin (see Fig. 7a.).

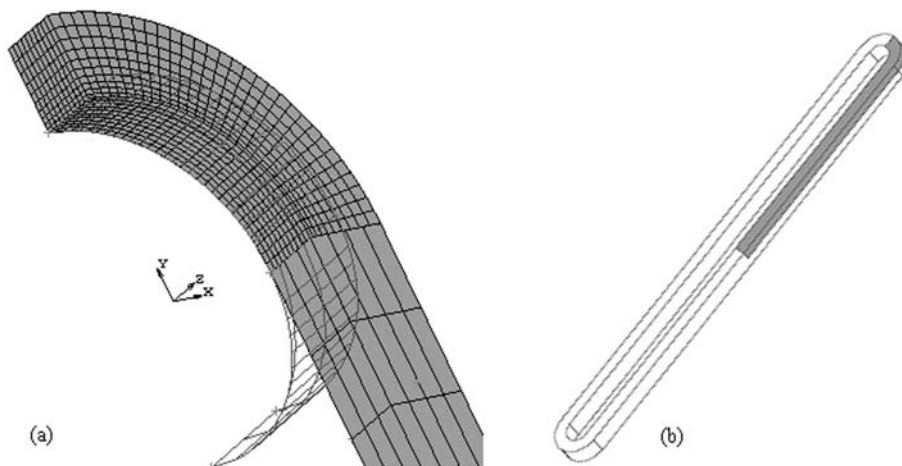

Fig. 7. (a) Mesh of numerical model; (b) Modelled one eighth of sample

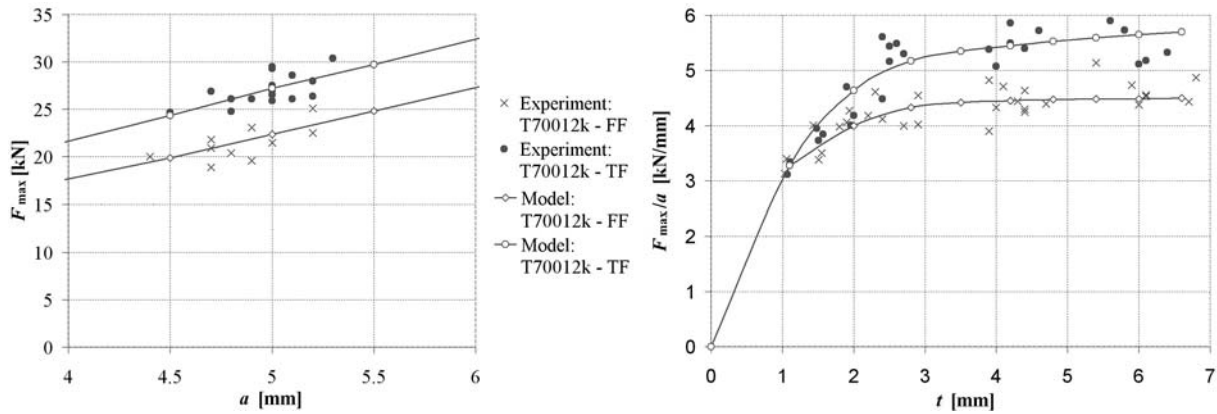

Fig. 8. Comparison of experimental and numerical results for  $d = 10$  mm,  $a = 5$  mm,  $V_f = 0.50$  [7]

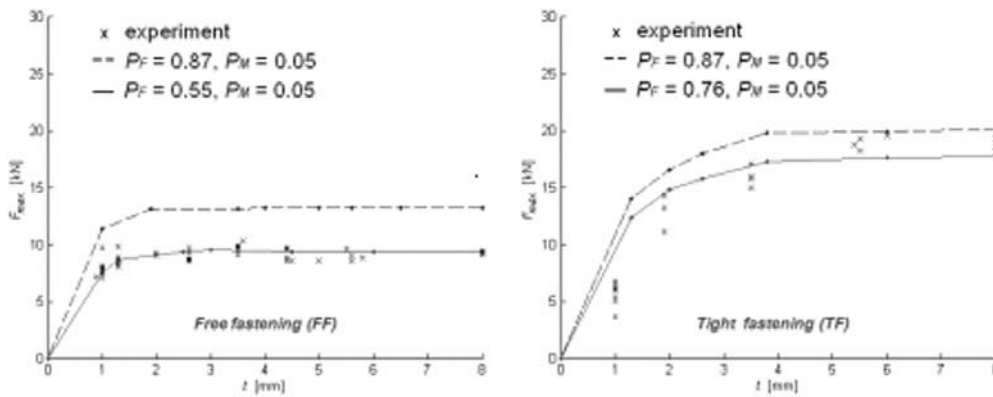

Fig. 9. Comparison of experimental and numerical results for  $d = 8$  mm,  $a = 3$  mm,  $V_f = 0.65$

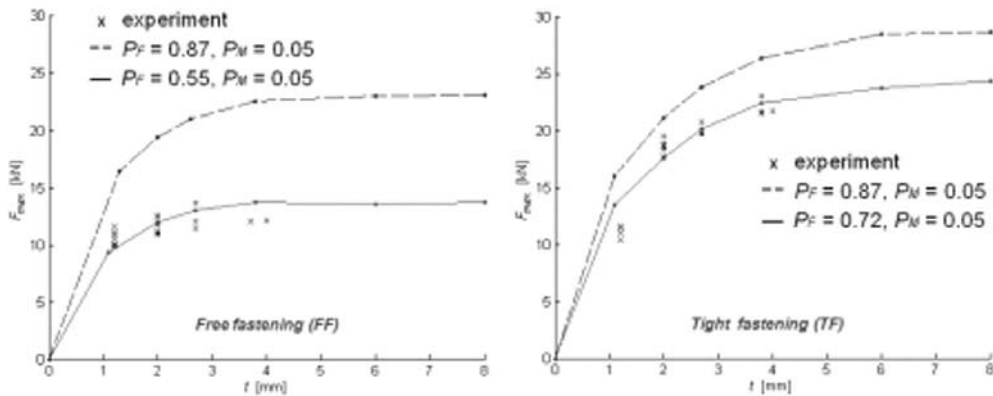

Fig. 10. Comparison of experimental and numerical results for  $d = 12$  mm,  $a = 3$  mm,  $V_f = 0.65$

The whole procedure of numerical simulation was automated. The parametrical creating of the numerical model of sample was created by means of scripts. These scripts were generated in system Matlab from designed geometric and material parameters.

The results of finite elements analysis (FEA) (with the adjusted criterion LaRC04) and tensile tests are shown in Fig. 8 [7]. This analysis was performed for samples with diameter  $d = 10$  mm and fiber volume of loop  $V_f = 0.50$ . The best agreement between experimental and numerical results was achieved for investigated geometries ( $d = 10$  mm,  $t = 1 \div 6.8$  mm,  $a = 4.4 \div 5.8$  mm) of samples and the fiber volume of loop  $V_f = 0.50$  for parameters (non-dimensional)  $P_M = 0.05$  and  $P_F = 0.87$  [7].

The comparison of the experimental and numerical results is shown in Fig. 9 and Fig. 10. The graphs show the dependences of the sample strength (maximal tensile force  $F_{max}$ ) on the sample thickness  $t$  for diameter  $d = 8$  mm (see Fig. 9) and diameter  $d = 12$  mm (see Fig. 10). The dashed curves are displayed for original parameters ( $P_M = 0.05$  and  $P_F = 0.87$ ). The solid curves are displayed for the new parameters. Using the new parameters, the best agreement between numerical and experimental results was achieved. The new values of the parameters are presented in the graphs. The fiber volume of loops was  $V_f = 0.65$  and width of loop was  $a = 3$  mm.

From mentioned results, good agreement between experimental results and numerical analysis was verified for adjustment of failure mode LaRC04#2 (matrix failure in compression in the transverse direction). This adjustment involves influence of stress in the longitudinal direction. The modification of failure mode LaRC04#2 for parameter  $P_M = 0.05$  is correct also in the case of pure compression in transverse direction or when stress in fiber direction is low, because the influence of the adjustment is very low in this case.

In case of failure mode LaRC04#3, the parameter  $P_F$  is different for different fiber volumes, i.e. different material properties and different geometry of sample. It is necessary to determine these parameters for specific material and geometry. Technique of identification of these parameters will be investigated in the future work.

The dependences of maximal tensile force (strength of sample) on combinations of two various geometrical parameters (third is constant) in case of TF samples from finite element analysis are shown in Fig. 11. Significant influence of width of sample  $a$  is obvious from those dependences. The sample strength increases proportionally with the width  $a$ . The influence of the loop thickness  $t$  is significant only up to determinate thickness (e.g. thickness  $t = 4$  mm for diameter  $d = 8$  mm). The influence of the sample thickness  $t$  on its strength increases with increasing diameter  $d$  (see Fig. 11b). In case of TF loops, the gradual linearization of the dependence of sample strength on inner diameter  $d$  occurs with increasing loop thickness (see Fig. 11b).

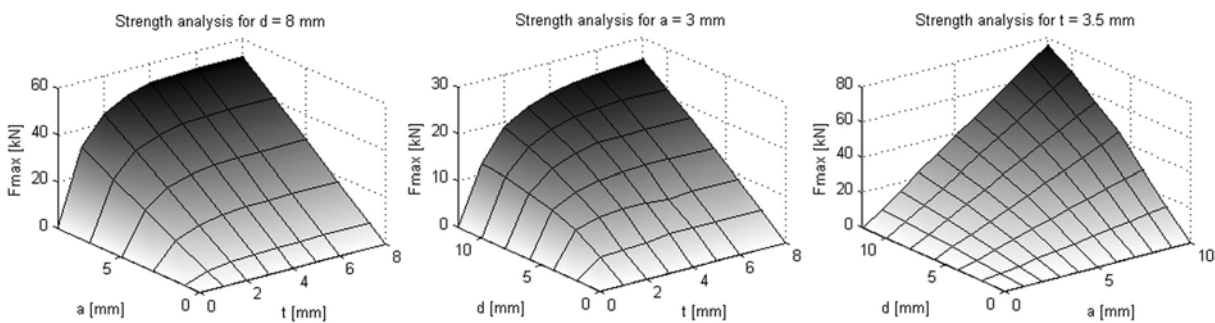

Fig. 11. FEA of TF samples for (a)  $d = 8$  mm, (b)  $a = 3$  mm, (c)  $t = 3.5$  mm

## 6. Conclusion

In the presented work, validation of the adjusted strength criterion LaRC04 for unidirectional composite under combination of tension and compression by means of comparison of experiments and numerical models for a wide range of samples was carried out. The numerical strength analysis was performed in finite element system MSC.Marc. The experimental samples were tested in tension. For the experiments, more than 150 samples with different geometries were manufactured and tested.

The results show good agreement between experimental results and numerical analysis for adjustment of failure mode LaRC04#2 (matrix failure in compression in the transverse direction), this adjustment involves influence of stress in the longitudinal direction, for the investigated range of samples.

In case of failure mode LaRC04#3, the parameter  $P_F$  is different for different fiber volume and different geometry of sample. It is necessary to determinate these parameters for specific material and geometry. Technique of identification of these parameters will be investigated in the future work.

## **Acknowledgements**

This paper includes partial results from the research project MŠMT 1M0519 — Research Centre of Rail Vehicles supported by the Czech Ministry of Education and partial results from the research project GAAS CR no. A200760611.

## **References**

- [1] Atas, C., Bearing strength of pinned joints in woven fabric composite with small weaving angles. *Composite Structures* 2009, 88, 40–45.
- [2] Dano, M. L., Gerdrón, G., Picard, A., Stress and failure analysis of mechanically fastened joints in composite laminates. *Composite Structures* 2000, 85, 287–296.
- [3] Dano, M. L., Kamal, E., Gendron, G., Analysis of bolted joints in composite laminates: Strains and bearing stiffness predictions. *Composite Structures* 2007, 79, 562–570.
- [4] Havar, T., Beitrag zur Gestaltung und Auslegung von 3D-Verstärkten Faserverbundsclaufen. Institut für Flugzeugbau der Universität Stuttgart, Stuttgart, 2007.
- [5] Hinton, M. J., Kaddour, A. S., Soden, P. D., Failure criteria in fibre reinforced polymer composites: The World-Wide Failure Exercise. Elsevier, 2004.
- [6] Kishore, A. N., Malhotra, S. K., Prasad, N. S., Failure analysis of multi-pin joints in glass fibre/epoxy composite laminates. *Composite Structures* 2009, 91, 266–277.
- [7] Kottner, R., Joining of composite and steel machine parts with special focus on stiffness and strength (in Czech). Doctoral thesis, University of West Bohemia, Plzeň, 2007.
- [8] Kottner, R., Kroupa, T., Krystek, J., Laš, V., Strength prediction of composite part of wrapped pin joint of composite/metal using FEA. Mechanical response of composite, Imperial College London, UK, 2009.
- [9] Kroupa, T., Damage of composites due to impact (in Czech). Doctoral thesis, University of West Bohemia, Plzeň, 2007.
- [10] Krystek, J., Kottner, R., Kroupa, T., Laš, V., Influence of geometric parameters of composite part of composite/metal wrapped pin joint on its strength. Machine Modelling and Simulation, Scientific and Technical Society at the University of Žilina, Slovensko, 2009.
- [11] Okutan, B., The effects of geometric parameters on the failure strength for pin-loaded multi-directional fiber-glass reinforced epoxy laminate. *Composites: Part B* 2002, 33, 567–578.
- [12] Pinho, S. T., Dávila, C. G., Camanho, P. P., Iannucci, L., Robinson, P., Failure Models and Criteria for FRP Under In-Plane or Three-Dimensional Stress States Including Shear Non-Linearity. Research report, NASA/TM-2005-213530, NASA Langley Research Center, 2005.
- [13] Withworth, H. A., Othieno, M., Barton, O., Failure analysis of composite pin loaded joints. *Composite Structures* 2003, 59, 261–266.